



**“Most advanced robotic arm in the world.”**

**Guinness World Records, Millennium Edition**



Low Active Power: 50 W  
Reach: 1 m

# WAM™ Arm

### Force-controllable robotic arm

The WAM™ Arm is a highly dexterous backdrivable manipulator. It is the only commercially available robotic arm with direct-drive capability supported by Transparent Dynamics™ between the motors and joints, so its joint-torque control is unmatched and guaranteed stable. It is built to outperform today’s conventional robots by offering extraordinary dexterity, zero backlash, and near-zero friction.

The WAM™ Arm is available in 3 main configurations, 4-DOF, 7-DOF, both with human-like kinematics, and 4-DOF with 3-DOF Gimbals (DOF = degrees of freedom). The joint ranges exceed those for conventional robotic arms.

All axes are driven by high-performance brushless motors, which use space-vector electronic commutation for the smoothest, most precise motions in both position and force control. Since the joints are highly backdrivable, true dynamic controls can be applied, resulting in much higher performance than is achievable with conventional manipulators. The high backdrivability enables inherent force-control, haptics, hybrid control, and teleoperation.

With its advanced and patented cabled differential, the WAM™ Arm is the ideal platform for implementing Whole-Arm Manipulation (WAM) techniques.

To operate in and around obstacles in the workspace, the arm link surfaces are simple, smooth, and slender to prevent task interference.

Combined with Whole-Arm force sensing, the WAM™ can manipulate large, heavy objects with the sides of its links as well as smaller objects with an attached grasper, such as the BarrettHand (shown left). Furthermore, the WAM™ Arm will operate with industrial grippers, end of arm tooling, and tool changers.

### No hassle, open source software

The new WAM™ Arm software enhances the customer’s ability to exploit the dynamic capabilities, key concepts and features, and extensive possibilities associated with the WAM™ Arm. Some of the highlighted features include “Teach and Play”, force control, and gravity compensation.

The Teach-and-Play software allows the user, including non-programmers, to record trajectories manually and play the same trajectories back at different speeds and accelerations with the touch of a key.

Force control of the robot in Cartesian space is as easy as calling a single high-level force function. If you prefer to have low-level control of the motor torques, the WAM™ also exposes the raw torque output functions which form the basis of the higher-level control.

The WAM™ Arm’s zero-gravity compensation permits the user to move the WAM™ Arm in a floating motion through any trajectory.

### Features

- No controller cabinet
- Low power
- AC or DC operation
- Superb payload-to-weight ratio
- Long, slender link structure
- High backdrivability
- Direct-teach recording without force sensors, with or without motor power, for safety
- Cartesian force control
- Gravity compensation
- Quiet operation
- Human-like kinematics
- Highest performance space-vector commutation
- Integrated current amplifiers
- Brushless motors
- Open-source C/C++ control software
- 1 kHz motor torque control
- Field-upgradeable firmware
- 4-wire bus (2 power, 2 communication)
- 2 auxiliary digital I/O signals per axis
- 2 auxiliary analog input signals per axis
- Joints never locked, for safety

Barrett Technology, Inc.  
625 Mount Auburn Street  
Cambridge, Massachusetts  
02138-4555 USA

[www.barrett.com](http://www.barrett.com)

### Applications



Mobile Platform Robotics



Whole Arm Haptics  
Rehabilitation Medical

Input voltage	Typ	48 V
Active power	Typ	50 W
	Peak	250 W
Reach	4-DOF	1000mm
	7-DOF	1000mm
Payload	4-DOF	4 kg
	7-DOF	3 kg
Endtip velocity	Max	1 m/s
Mass of robot	4-DOF	25 kg
	7-DOF	27.2 kg
Work volume		3.5 m <sup>3</sup>
Repeatability	4-DOF	1000μm
	7-DOF	2000 μm
...with joint encoder option	4-DOF	100 μm
	7-DOF	200 μm
Total joint friction		3 Nm
Mechanical stiffness		1.5E6 N/m
Control stiffness		5000 N/m

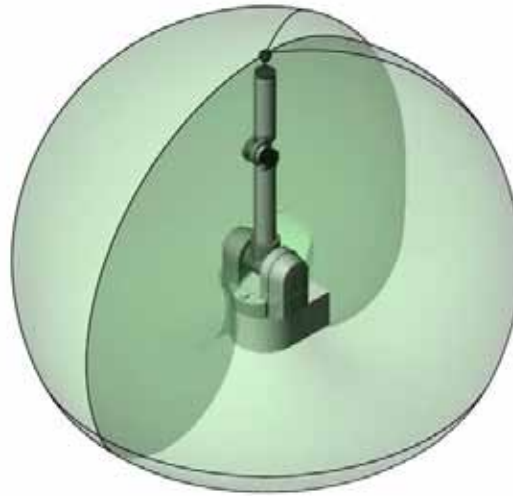

Workspace, Isometric View

TECHNICAL SPECIFICATIONS SUBJECT TO CHANGE WITHOUT NOTICE  
©2010 BARRETT TECHNOLOGY, INC.

The Barrett WAM™ has a nearly spherical workspace approximately 2 meters in diameter.

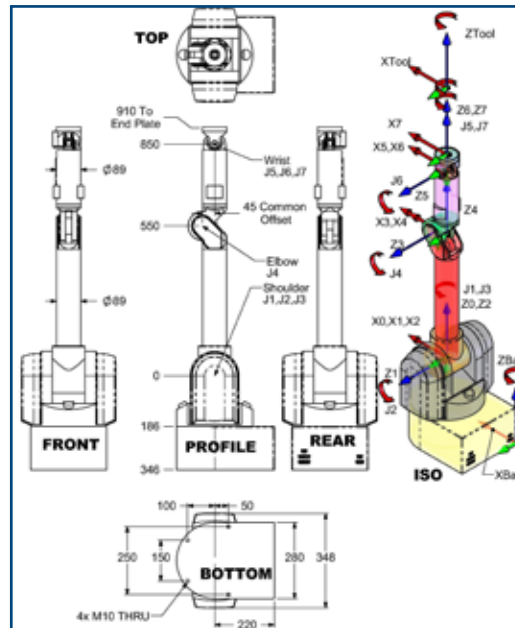
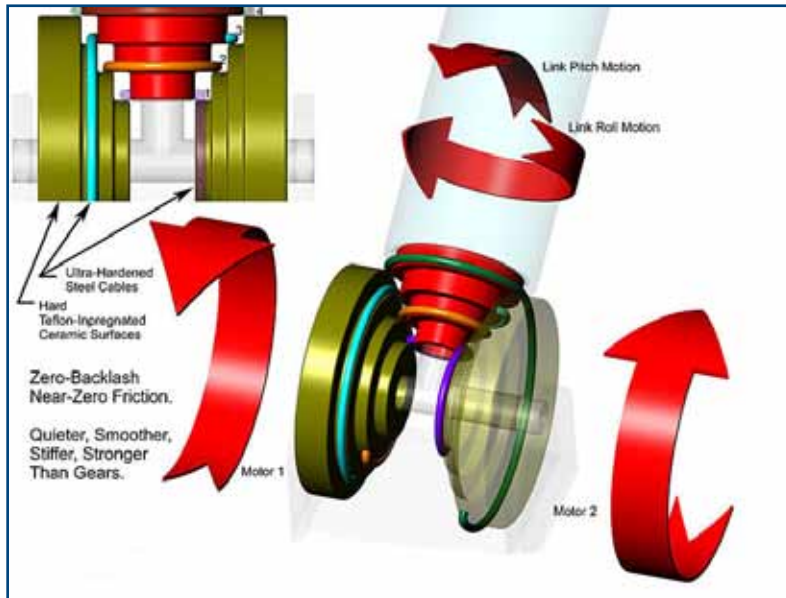

Barrett's Patented WAM™ Cable-Differential



**Barrett Technology™ Inc.**

625 Mount Auburn Street  
Cambridge, Massachusetts  
02138-4555 USA

T +617.252.9000  
F +617.252.9021

[www.barrett.com](http://www.barrett.com)

revAB-092010